



OPERATION & MAINTENANCE MANUAL

for

DOUBLE SUCTION SPLIT CASE PUMPS

**PATTERSON PUMP COMPANY
A SUBSIDIARY OF THE GORMAN-RUPP COMPANY
PO Box 790
2129 Ayersville Road
Toccoa, Georgia 30577
Telephone: 706-886-2101
Fax: 706-886-0023
SAFETY PRECAUTIONS**

WARNING

Do not operate this equipment in excess of its rated speed or other than in accordance with the instructions contained in this manual.

The equipment has been found satisfactory of the conditions for which it was sold, but its operation in excess of these conditions may subject it to stresses and strains which it was not designed to withstand.

For equipment covered by this instruction book, it is important to observe safety precautions to protect personnel from possible injury. Among the many considerations, personnel should be instructed to:

- avoid contact with rotating parts
- avoid bypassing or rendering inoperative any safeguards or protective devices
- avoid extended exposure in close proximity to machinery with high noise levels
- use proper care and procedures in handling, lifting, installing, operating and maintaining the equipment
- do not modify this equipment – consult factory if modification is deemed necessary
- do not substitute for repair parts which can be provided by the equipment manufacturer.

Safe maintenance practices with qualified personnel are imperative.

Failure to heed this warning may result in an accident causing personal injury.

TABLE OF CONTENTS

SECTION I:	General Information	1
SECTION II:	Storage & Protection	1
SECTION III:	Installation	
	3-1 Location	2
	3-2 Foundation	2
	3-3 Mounting	2
	3-4 Alignment	3
	3-5 Grouting	6
	3-6 Piping	6
SECTION IV:	Operation	
	4-1 Starting	8
	4-2 Shutdown	9
	4-3 Minimum Flow Limitation	9
SECTION V:	Maintenance	
	5-1 Lubrication	10
	5-2 Stuffing Box	11
	5-3 Wear Ring Clearance	11
SECTION VI:	Repairs & Replacement	
	6-1 To Remove Rotor	15
	6-2 Disassembly of Rotating Element	15
	6-3 To Remove Impeller Rings	16
	6-4 Inspection	16
	6-5 Assembly	19
	Locating Operation Difficulties	20-21
	Recommended Spare Parts	22

SECTION I

GENERAL INFORMATION

This manual covers the installation, operation and maintenance of Patterson Pump horizontal split case pumps. The pump is a centrifugal, single stage, double suction type. When properly installed and when given reasonable care and maintenance, centrifugal pumps should operate satisfactorily for a long period of time. Centrifugal pumps use the centrifugal force principal of accelerating the liquid within a rotating impeller, and then collecting it and converting it to pressure head in a stationary volute.

The pump consists of two assemblies:

1. Casing assembly or stationary part
2. Rotating element or moving part

This casing is split along the horizontal centerline of the pump shaft, suction and discharge nozzles both being located in the lower half. With this arrangement, it is not necessary to disconnect suction or discharge piping to make repairs to, or replace the rotating element. Upper and lower half casings are bolted together and doweled to maintain a smooth volute contour inside the pump. Supporting feet are integrally cast in the lower half casing and are drilled for bolting and doweled to base plate. Bearing brackets form a drip pocket for collecting stuffing box leakage and are provided with drilled and tapped connections for draining. The brackets also contain an overflow hole to release the water before it reaches the shaft, in case drain piping should become clogged. Suction and discharge flanges are drilled and tapped for gauge connections. Pump suction and discharge nozzles are drilled and tapped on the underneath side for complete pump drain. Wear rings are provided to minimize internal bypassing of the liquid being pumped, and to better efficiency, as well as to reduce the replacement of major components (such as casing and impeller).

SECTION II

STORAGE & PROTECTION

All pumps are shop serviced and ready for operation when delivered, but there is occasions when considerable time elapses between the delivery date and the time the pump is put into operation. Equipment, which is not in service, should be kept in a clean, dry area. If equipment is to be stored for long periods of time (six months or more), the following precautions should be taken to insure that the equipment remains in good condition.

1. Be sure that the bearings are fully lubricated.
2. Unpainted-machined surfaces, which are subject to corrosion, should be protected by some corrosive resistant coating.
3. The shaft should be rotated 10 to 15 revolutions by hand periodically in order to spread the lubricant over all the bearing surfaces. Suitable intervals are from one to three months, depending on atmospheric conditions, etc. In order to insure that the pump shaft does not begin to sag, do not leave the shaft in the same position each time.

Section II – Storage & Protection Continued

4. Space heaters on motors and controllers should be connected and fully operable if atmospheric conditions approach those experienced in operation. Consult instruction manuals for other precautions concerning storage of individual components of pumping unit.
5. Fresh lubricant must be applied to bearings upon removal of equipment from storage.

SECTION III

INSTALLATION

3-1 Location:

Several factors should be considered when selecting a location for the pumping unit (pump, base, drive, and coupling). The unit should be accessible for both inspection and maintenance. Headroom should be provided for the use of crane, hoist or other necessary lifting devices. The pump should be located as close as possible to the liquid supply so that the suction line is short and direct. Location should require a minimum of elbows and fittings in the discharge line to minimize friction losses. The unit should be protected against flooding.

3-2 Foundation:

The foundation should be sufficiently substantial to absorb vibration and to form a permanent rigid support for the base plate. Concrete is most widely used for foundation. Before pouring the foundation, locate anchor bolts per outline drawing. Allow for 3/4 inch to 1 1/2 inch of grout between foundation and base plate. The top surface of the foundation should be roughened to provide a good bond for the grout.

3-3 Mounting:

WARNING!!! Do not attempt to lift entire unit using lugs provided on either pump or motor only. Such action may lead to failure of the lugs and possible damage to the unit or injury to personnel. Lift unit with slings around the base plate, or by attaching cables to the lifting lugs on both the pump and the motor.

Coupling halves should be disconnected when mounting the pumping unit on the foundation. Wedges should be used to support the unit at the time of grouting. Wedges should be located adjacent to anchor bolts (one on each side of bolt) and midway between bolts. Adjust the wedges to raise or lower the unit as required to align suction and discharge flanges to piping and to level the base plate. Leveling bolts made of cap screws and nuts are useful when leveling large base plate, but should not replace shims or blocks for supporting the load. After unit has been in operation for about a week, check alignment. After making any required adjustments, dowel pump and motor to base.

Section III – Installation Continued

3-4 Alignment:

The pump unit has been manufactured to allow field alignment. The unit must be properly aligned at the time of installation. Reliable trouble-free and efficient operation of a unit depends upon correct alignment. Misalignment may be the cause of noisy pump operation, vibration, premature bearing failure, or excessive coupling wear. Factors that may change the alignment of the pumping unit are settling of the foundation, springing of the base plate, piping strains, a shift of the pump or drive on the foundation. When checking coupling alignment, remember flexible couplings are not intended to be used as universal joints. The purpose of a flexible coupling is to compensate for temperature changes and to permit end movement of the shafts without interference with each other.

Two types of misalignment may exist: parallel misalignment and angular misalignment. Limits of misalignments are stated in the coupling manufacturer's instructions, but should be kept to a minimum for maximum life of equipment components.

To check coupling alignment, the following procedure should be followed:

1. Set the coupling gap to the dimension shown on the outline drawing.
2. Check for parallel misalignment by placing a straight edge across both coupling halves at four points 90° apart. Correct alignment occurs when the straight edge is level across the coupling halves at all points.
3. Check angular misalignment with a feeler gauge at four points 90° apart. Correct alignment occurs when the same gauge just enters between the halves at all four points.

Angular and parallel misalignment are corrected by shifting the motor and adding or removing shims from under the motor feet. After each change, it is necessary to recheck the alignment of the coupling halves. Adjustment in one direction may disturb adjustment already made in another direction.

An alternative method for checking coupling alignment is by use of a dial indicator. Proceed as follows:

1. Scribe index lines on coupling halves or mark where the indicator point rests.
2. Set indicator dial to zero.
3. Slowly turn both coupling halves so that the index lines match, or the indicator point is always on the mark.
4. Observe dial reading to determine whether adjustments are needed. Acceptable alignment occurs when total indicator reading does not exceed 0.004 inches for both parallel and angular alignment.

The importance of correct alignment cannot be overemphasized. Alignment should be checked and corrected as required after:

1. Mounting
2. Grouting has hardened
3. Foundation bolts are tightened
4. Piping is connected
5. Pump, driver, or base plate is moved for any reason.

WARNING!!!

The importance of correct alignment cannot be overemphasized. The following procedure should be used for initial installation.

1. Place complete pump assembly on anchor bolts allowing room under the base plate for leveling wedges or shims. Make sure the base plate is level by using the leveling wedges adjacent to the foundation bolts and midway between the bolts.
2. Put nuts on the anchor bolts and tighten evenly, but not too tight.
3. At this point check alignment of the coupling. This should not be more than that recommended by the coupling manufacturer.
4. If misalignment is evident, determine which direction the coupling needs to be moved.
5. Loosen all nuts and add the shims underneath the base plate at the opposite corners. Use the anchor bolts to flex the base plate to bring the coupling into alignment.
6. After the alignment has been made with all anchor bolt nuts tight, the grouting can take place.
7. After grouting is completed, final alignment should be checked to be sure it is within allowable tolerances. Use of shims under the driver can be used to obtain final alignment.

Alignment should be checked and corrected as required after:

- Mounting
- Foundation bolts are tightened
- Grouting has hardened
- Piping is connected
- Pump, driver, or base plate is moved for any reason

3-5 Grouting:

Grout compensates for unevenness in the foundation and distributes the weight of the unit uniformly on the foundation. It also prevents lateral shifting of the base plate and reduces vibration. Use a non-shrinking grout. Foundation bolts should be tightened evenly, but not too firmly. Grout the unit as follows:

1. Build a strong form around the base plate to contain the grout.
2. Soak the foundation top thoroughly, and then remove surface water.
3. Pour grout. Tamp liberally while pouring in order to fill all cavities and prevent air pockets. The space between the foundation and base plate should be completely filled with grout. In order to prevent the base plate from shifting, fill under the base plate at least four inches in from all four edges. Wedges may be left in place.
4. After the grout has hardened (usually about 48 hours), thoroughly tighten foundation bolts and check alignment.
5. Approximately 14 days after the grout has been poured or when it is thoroughly dry, apply an oil base paint to exposed edges of the grout to prevent air and moisture from coming in contact with the grout.

3-6 Piping:

Connect pipelines after the grout has thoroughly hardened. The suction and discharge piping should be installed with the shortest and most direct runs. Elbows should preferably be of the long radius type. Pipes must line up naturally. The piping must never be pulled into position by the flange bolts. Such action may draw the pump out of alignment. Pipes should be support independently of the pump so as not to put any strain on the pump casing. Suction piping, if not properly installed, is a potential source of faulty operation. Suction lines should be free of air leaks, and arranged so there are no loops or high spots in which air can be trapped. Generally, the suction line is larger than the pump suction nozzle, and eccentric reducers should be used. Eccentric reducers are not necessary for bottom suction pumps. If the liquid supply is located below the pump centerline, the reducer should be installed with the straight side up.

Most often air enters the suction pipe entrained in the liquid. Installations with a static suction lift preferably should have the inlet of the vertical suction piping submerged in the liquid to four times the piping diameter. A large suction pipe will usually prevent the formation of vortexes or whirlpools, especially if the entrance is flared (Figure 5). A floating vortex breaker (raft) around the suction piping may be provided if a tendency appears for a vortex to form at the liquid surface. A stream of liquid falling into the sump near the intake pipe will churn air into the liquid (Figure 6). The supply line should extend down into the sump. Liquid supply entering a well perpendicular to the intake line tends to rotate the liquid, which interferes with the flow into the suction line (Figure 7). A baffle placed in front of the supply pipe will remedy this situation. A short elbow should never be bolted directly to the pumps suction nozzle. The disturbance in the flow caused by the sharp bend so near the pump inlet may result in noisy operation, loss in efficiency, and capacity, and heavy end thrust.

A long sweep or long radius elbow placed as far away from the pump as practicable should be used if a bend is necessary in the suction line. If separate suction lines cannot be used for each pump, then a tapering header with Y-branches should be used (Figure 8A). A straight branch header should never be used. Prior to installing the pump, suction piping and pump should be inspected internally, cleaned and flushed. If a strainer is installed in the suction line, the openings in the screen must be checked and cleaned periodically. The opening must be smaller than the sphere size allowed by the impeller.

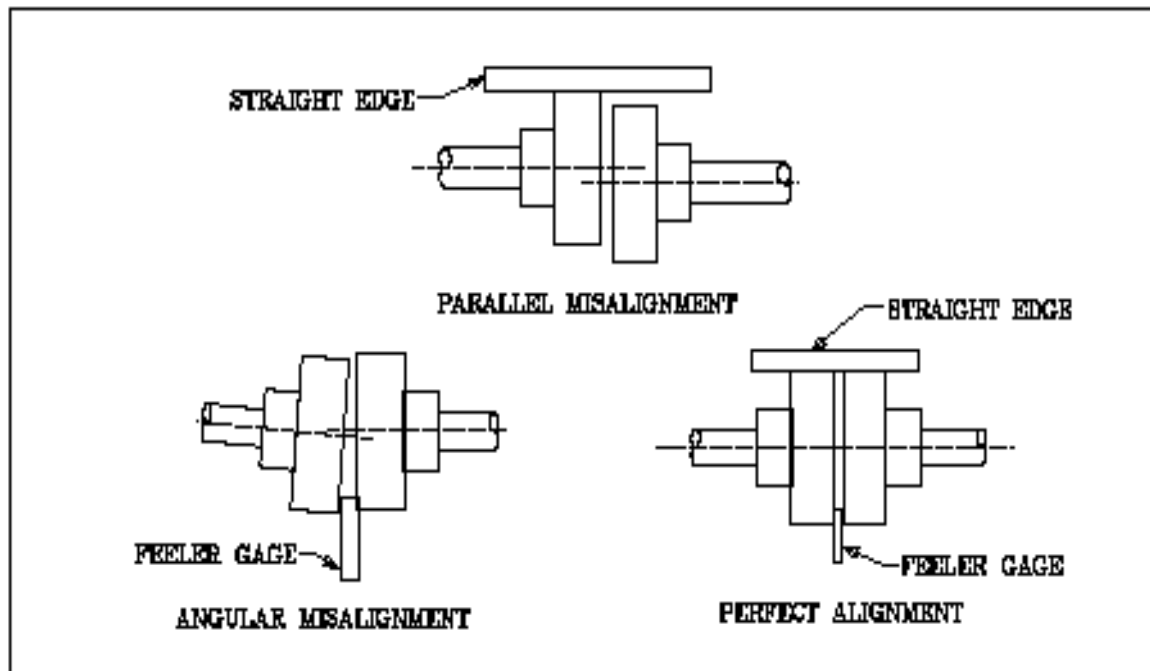

FIG. 1 TESTING ALIGNMENT, STRAIGHTEDGE

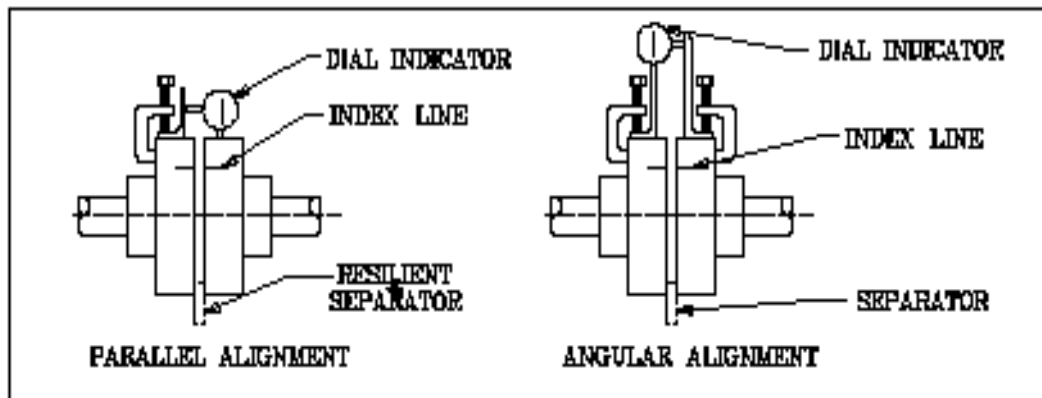

FIG. 2 TESTING ALIGNMENT, DIAL INDICATOR

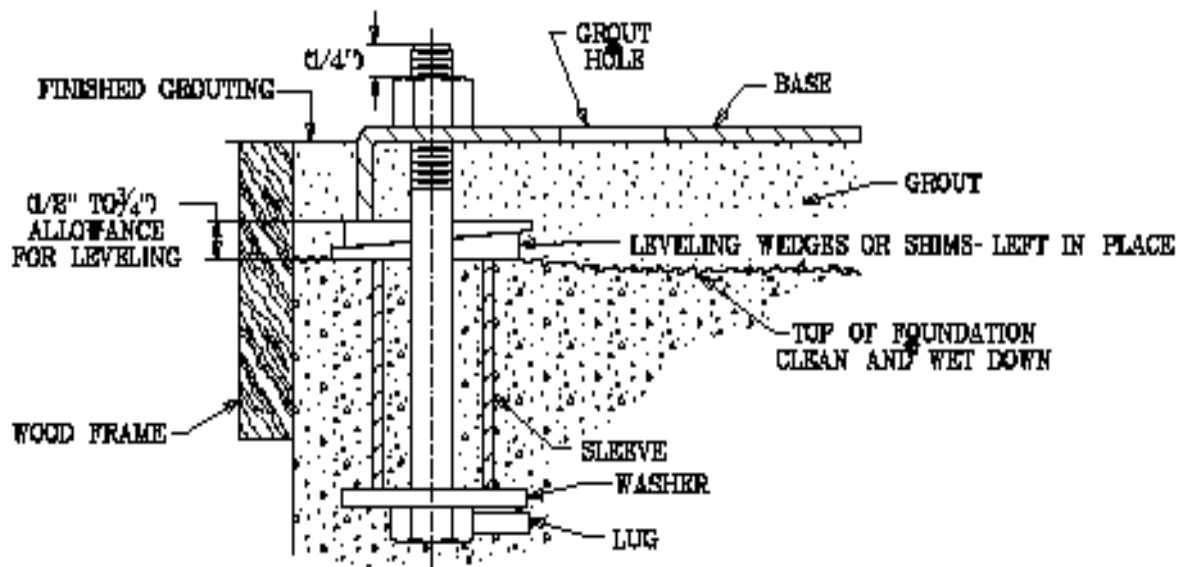

FIG. 3 TYPICAL FOUNDATION BOLT DESIGN

Section III – 3-6 Piping Continued

Discharge piping should be installed with check valve and gate valve, with the check valve being between the pump and the gate valve. The check valve prevents reverse flow and protects the pump from excessive backpressure. The gate valve is used to isolate the pump for maintenance, priming and starting. If a diffuser is used, it should be placed between the pump and check valve.

Stuffing box seal connections are usually made from the top of the pump casing. If the liquid being pumped is unsuitable for sealing, then it is preferable to bring fresh, cool water to seal connections from an outside source. Centrifugal separators or other filters may be used to remove abrasive particles from the liquid being pumped if an outside source is not available. After all piping connections have been made, the alignment should be checked again.

SECTION IV

OPERATION

Before bolting the coupling halves together, check the drive rotation to see that it matches the pump rotation. Pump rotation is indicated by an arrow attached to the casing assembly. For a three-phase motor, rotation may be reversed, if necessary, by interchanging any two of the three power leads. Rotation of single-phase motors is fixed by internal wiring.

WARNING!!! Prior to startup, check the coupling alignment as covered in the **Installation Section**. Operation of the pump with the unit misaligned will cause damage to the shaft, bearings, and the coupling.

4-1 Starting:

- When possible, turn the pump shaft by hand to insure that the parts do not bind
- Check the bearing lubricant
- Open the valve in the pump suction line, if fitted
- Close discharge valve
- Prime the pump in one of the following ways:
 1. If the pump operates under positive pressure, open vent valve on top of the pump casing. After all entrained air has escaped, close the vent valves. Rotate the shaft, if possible, to allow any air trapped in the impeller passages to escape.
 2. If the pump operates on a suction lift and a foot valve is included in the system, fill the pump and the suction line with liquid from an outside source. Trapped air should be allowed to escape through the vent valve while filling.
 3. If the pump operates on a suction lift and no foot valve is provided, use a vacuum pump or ejector operated by air, steam, water, etc. to evacuate air from the pump case and suction line by connecting the ejector to the priming connection on top of the pump case.

Open valves in stuffing box seal lines, if fitted. Start driver. Open discharge valve slowly when the pump is up to speed.

CAUTION: Overheating and/or loss of prime will result if the pump is operated against a closed valve for more than a few minutes.

WARNING !!! The coupling guard should be in place when the unit is started. Stay clear of any exposed rotating parts while the pump is operating. Contact with rotating parts may result in injury to personnel.

Adjust the packing gland until there is a slight leakage from the stuffing box. **(See Maintenance on Adjustment of Packing)**. Mechanical seals need no adjustment. There should be no leakage.

NOTE: Should the pump fail to build up pressure or discharge water when the discharge valve is opened, stop the pump and read **Section Locating Operating Difficulties**.

4-2 Shutdown

The pump may be stopped with the discharge valve open without causing damage. However, in order to prevent water hammer effects, the discharge valve should be closed first.

1. Close discharge valve.
2. Stop driver.
3. Close water seal valves.
4. Close valve in the pump suction line, if fitted. If danger of freezing exists, drain the pump completely.

4-3 Minimum Flow Limitation

All centrifugal pumps have limitations on the minimum flow at which they should be operated. The most common limitation is to avoid excessive temperature buildup in the pump because of absorption of the input power into the pumped fluid. Other less understood reasons for restrictions are:

1. Increased radial reaction at low flows in single volute casings.
2. Increased NPSHR at low flows.
3. Noisy, rough operation and possible physical damage due to internal recirculation.
4. Increased suction and discharge pulsation levels.

The size of the pump, the energy absorbed, and the liquid pumped are among the considerations in determining these minimum flow limitations. For example, most small pumps such as domestic home circulators, service water pumps, and chemical pumps have no limitations, except for temperature buildup considerations while many large, high horsepower pumps have limitations as high as 40-50% of the best efficiency point capacity. The minimum safe flow for this pump is given under **Pump Specifications**.

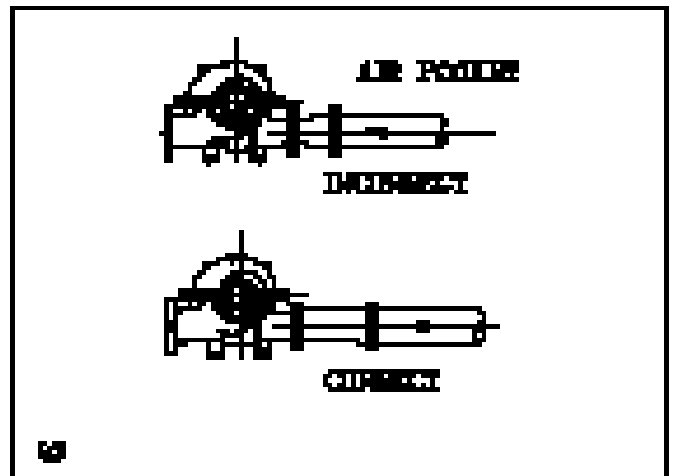
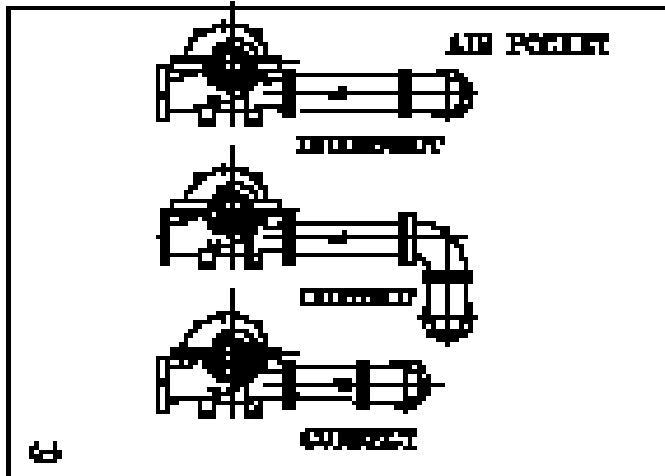
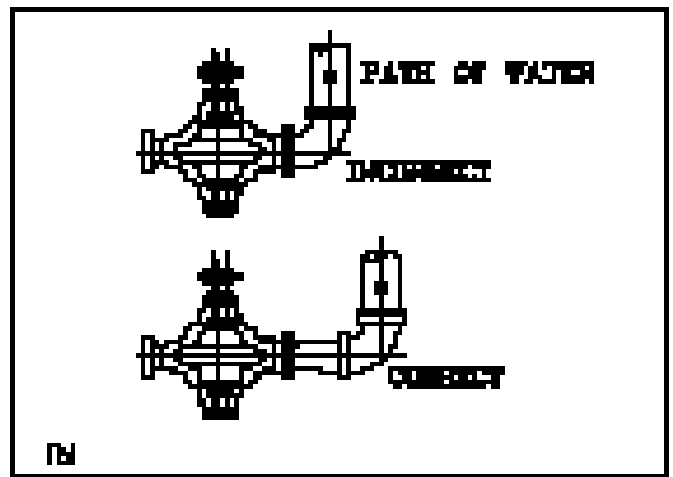
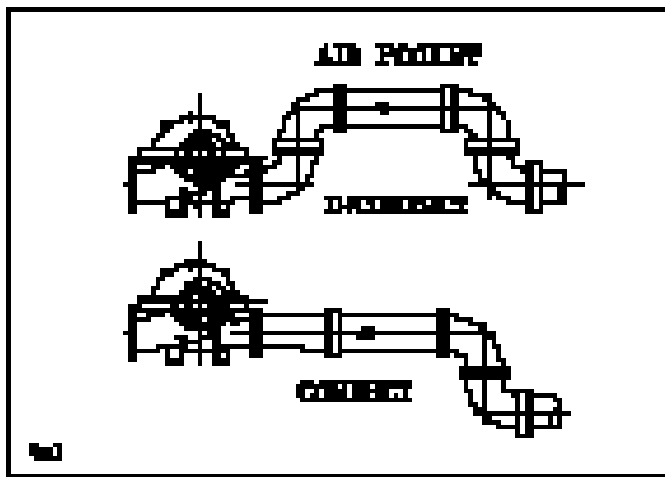

FIG. 4. SUCTION PIPE ARRANGEMENTS

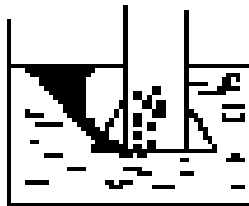

Fig. 5 Enlarging the suction pipe usually prevents whirl-pools and the resultant entrance of air into the pipes

FIG. 5

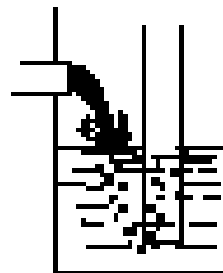

Fig. 6a Water falling into pump causes air into the pump liquid seal causes trouble in the suction line

Fig. 6a

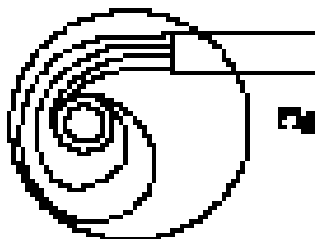

Fig. 7 Rotation of water in the wall, as illustrated, can be prevented with a baffle

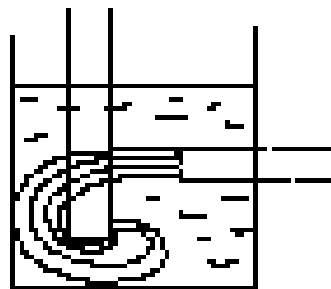

Fig. 6b Supply line should extend down into the pump to prevent the drawing of air into the water.

Fig. 6b

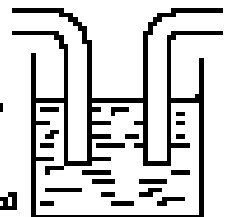

FIG. 6d

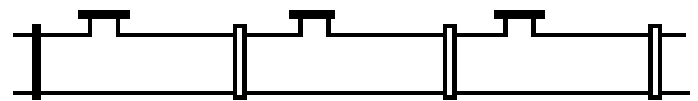

Fig. 6e

Fig. 6d Shows the tapering header which should be used if two or more pipes are served with one intake line the pipe shown in Fig. 6e should never be used

SECTION V

MAINTENANCE

5-1 Lubrication:

Couplings: Couplings with rubber drive elements do not require lubrication. Most other couplings require some form of lubrication. Consult manufacturer's instructions for recommendations.

Bearings: Frequency of lubrication depends upon operating conditions and environment, therefore, lubrication intervals must be determined by experience. Table I may be used as a general guide for grease relubrication. Lubricants need replacing only because of contamination by dirt or dust, metal particles, moisture or high temperature breakdown. A small amount of grease may be added about every 400 hours of operation. The bearing housing should be about 1/3 full of grease. Oil lubricated units are provided with constant level oilers. Bottles should be kept filled at all times so that there is a visible supply of oil. All lubricants have a tendency to deteriorate in the course of time, therefore, sooner or later it will be necessary to replace the old lubricant with new. Bearings, which are dismantled, are, of course, much more easily cleaned than bearings, which stay in assembled equipment. Solvents may be used more freely and effectively. For cleaning bearings without dismounting, hot light oil at 180° - 200° F may be flushed through the housing while the shaft is slowly rotated. Light transformer oils, spindle oils, or automotive flushing oils are suitable for cleaning bearings, but anything heavier than light motor oil (SAE 10) is not recommended. The use of chlorinated solvents of any kind is not recommended in bearing cleaning.

Grease Relubrication: (pumps are shipped with grease in bearing housings)

1. Thoroughly clean grease fitting and outside of bearing housing.
2. Remove drain plug.
3. Inject clean, new grease forcing out the old.
4. Start and run the pump for a short time to eject any excess grease.
5. Wipe off all excess grease and replace drain plug.

Oil Relubrication: (pumps are shipped without oil in bearing housing)

1. Remove drain plug and allow any residue oil to completely drain.
2. Remove constant level oiler bottle and clean thoroughly.
3. Replace drain plug.
4. Fill bottle, screw it to the lower reservoir of oiler and allow oil to flow into bearing housing reservoir. Repeat this procedure until a supply of oil remains in the bottle.

For ball bearings, the oil level should be at about the middle of the lower most ball. For ring oiled sleeve bearings, the oil level should be about 1/8 inch over the lowest point of the oil ring.

WARNING !!! Proper lubrication is essential to the pump operation. Do not operate the pump if sufficient lubricant is not present in the bearing housing or if lubricant is contaminated with excessive dirt or moisture. Operation of the unit under

these conditions will lead to impaired pump performance, and possible bearing failure. Do not operate the pump with excessive amount of lubricant. Such action will cause bearings to overheat.

5-2 Stuffing Box:

The purpose of a stuffing box is to limit or eliminate leakage of the pump fluid and to prevent air from entering the suction spaces along the pump shaft. Pumps are equipped with packing (limited leakage) or mechanical seals (no leakage). Normally, the pumped liquid is used to lubricate the stuffing box seal. If the liquid is dirty, gritty, or contains material that would gum or jam the seal, use a sealing liquid from an external source. If suction pressure is above atmospheric pressure, seal piping may not be required. For pumps equipped with packing, there must always be a slight leakage from the glands. The amount of leakage is hard to define, but we recommend a steady dripping of liquid through the gland. Stuffing box glands should be adjusted after the pump is started. When leakage is excessive, tighten gland bolts evenly a little at a time. Allow an interval for packing to adjust to new position. Never tighten gland to be leakproof, as this will cause overheating and undue wear on shaft sleeves.

Replace stuffing box packing as follows:

1. Shutdown the pump.
2. Take precautions to prevent the driver from being inadvertently started.
3. Remove the gland bolt nuts and gland.
4. Remove and discard old packing rings – note location of lantern ring. When repacking stuffing box, lantern ring must be positioned such that the water seal connection is opposite lantern ring.
5. Clean out the stuffing box.
6. Inspect shaft sleeve for wear – if it is scored or grooved, it should be replaced.
7. Make sure the stuffing box bushing (if furnished) is set at the bottom of the box.
8. Insert rings of packing and tap lightly to seat against bushing. Be sure rings are of the proper size and length and installed with cuts staggered. Lantern ring **must** be installed opposite sealing water connection.
9. Install gland and tighten, finger tight. With the pump running, adjust gland as described previously. Care should be taken during the first hour of operation to take up on the packing gradually just enough to maintain the required amount of leakage.

If the pump is operated daily, the stuffing box packing should be renewed about every two to three months before it gets hard and scores the shaft sleeves.

Mechanical seals should be removed, assembled, and/or adjusted according to the seal manufacturer's instructions. There should be no leakage from the gland if mechanical seals are used, except for a brief run in period.

5-3 Wear Ring Clearance:

Running fits between wear rings is given under the pump specifications. When these clearances are doubled, or the capacity of the pump is reduced by 5 to 10%, the rings should be renewed. The purpose of these rings is to keep internal bypassing of the liquid being pumped to a minimum. Clearances should be checked periodically and whenever the pump casing is opened. Check with feeler gauge or by direct measurement. Measure ID of case ring and OD of impeller ring, then compute clearance (ID minus OD).

**TABLE 1
SUGGESTED RE-LUBRICATION INTERVALS FOR VARIOUS
ENVIRONMENTAL, OPERATING AND TEMPERATURE CONDITIONS
(GREASE LUBRICATED BEARINGS)**

AMBIENT CONDITIONS		OPERATING CONDITIONS		BEARING OPERATING TEMPERATURE		SUGGESTED GREASING INTERVALS**	USE THESE GREASES
Dirt	Moisture	Load	Speed	Low	High		
Clean	Dry	Light to medium	Slow to medium	0°F (-18°C)	120°F (49°C)	2 to 6 months	High quality NGLI No. 1 or 2 multipurpose bearing greases are generally satisfactory. Consultation with a reputable lubricant supplier is recommended.
Moderate to dirty	Dry	Light to medium	Slow to medium	120°F (49°C)	200°F (93°C)	1 to 2 months	
				0°F (-18°C)	120°F (49°C)	1 to 4 weeks	
Extreme dirt	Dry	Light to medium	Slow to medium	120°F (49°C)	200°F (93°C)	1 to 7 days	
		Light to medium	Slow to medium	0°F (-18°C)	200°F (93°C)	Daily flushing out dirt	Lithium or other corrosion control grease
	High humidity Direct water Splash	Light to heavy	Slow to medium	32°F (0°C)	200°F (93°C)	1 to 4 weeks grease at shutdowns	
		Heavy to very heavy	Slow	0°F (-18°C)	200°F (93°C)	1 to 8 weeks	High viscosity lubrication
				-20°F (-29°C)	120°F (49°C)	1 to 8 weeks	
		Light	High speed	100°F (38°C)	200°F (93°C)	1 to 8 weeks	Channeling (high speed) type grease
	Possible frost	Light to heavy	Slow to medium	-65°F (-54°C)	+250°F (121°C)	1 to 4 weeks grease at shutdown	Wide temperature range Diester-type greases (Silicone-Diester-Polyester lubricants)
Clean to moderate	Dry	Light to medium	Slow to medium	80°F (27°C)	250°F (121°C)	1 to 8 weeks	Good quality high temperature type greases
Clean to dirty	Dry	Light	Slow	80°F (27°C)	300°F (149°C)	1 to 4 weeks	Synthetic type greases

**Suggested starting interval for maintenance program. Check grease conditions for oiliness and dirt and adjust greasing frequency accordingly. Watch operating temperatures as sudden rises may show need for grease or indicate over lubrication on higher speed applications.

TABLE II
RECOMMENDED GREASES

Use NLGI Grade 2 grease

Such As:

COMPANY	GREASE
Chevron	SRI
CITGO	Premium Lithium EP2
Exxon	Lidok EP2
Keystone	81EP2
Pennzoil	PennLith 712
Shell	Alvania EP2
Texaco	Multifak EP2

WARNING!!! Use of lubricants other than those listed or their equivalent will cause reduced pump performance and reduce bearing life.

TABLE III
RECOMMENDED OILS

	SPEED RANGE (RPM)	
	1800 and Over	1500 and Below
	VISCOSITY RANGE	
MANUFACTURER	145 SSU TO 175 SSU @100°	270 SSU TO 375 SSU @100°
MOBIL OIL COMPANY	MOBIL DTE 797	DTE OIL HEAVY MEDIUM
SHELL OIL COMPANY	TELLUS 927	TELLUS 933
TEXACO, INC.	REGAL A (R & O)	REGAL PC (R & O)
STANDARD OIL COMPANY	CHEVRON OC TURBINE 9	CHEVRON OC TURBINE 15
HUMBLE OIL & REFINING COMPANY	TERESSTIC OR TERESSO 43	TERESSTIC OR TERESSO 52
GULF OIL CORPORATION	HARMONY 44	HARMONY 53
UNION OIL OF CALIFORNIA	RED LINE TURBINE 150	RED LINE TURBINE 300
RICHFIELD DIVISION	EAGLE R & O NO. 10	EAGLE R & O LIGHT
ATLANTIC DIVISION ATL. RICH.	HYTHERM C	HYTHERM F
AMERICAN OIL COMPANY	AMER INDUSTRIAL OIL NO. 15	AMER INDUSTRIAL OIL NO. 31
CITIES SERVICE OIL COMPANY	CITGO PACEMAKER T-15	CITGO PACEMAKER T-30
CONTINENTAL OIL COMPANY	CONOCO DECTOL NO. 15 R & O	
E.F. HOUGHTON & COMPANY	HYDRO-DRIVE MIH LIGHT	HYDRO-DRIVE MIH-20
KEYSTONE LUBRICATING COMPANY	KLC-6	KLC-4A
PENNZOIL COMPANY	PENNBELL NO. 1	PENNBELL NO. 3
PHILLIPS PETROLEUM COMPANY	MAGNUS OIL 150	
PURE OIL COMPANY		PUROPALE RX HEAVY MEDIUM
SINCLAIR REFINING COMPANY	DURO 150	DURO 300
SUN OIL COMPANY	SUNVIS 916	SUNVIS 931

WARNING!!! Use of lubricants other than those listed or their equivalent will cause reduced pump performance and reduce bearing life.

SECTION VI

REPAIRS AND REPLACEMENT

WARNING!!! Whenever any disassembly work is to be done on the pump, disconnect the power source to the driver to eliminate any possibility of starting unit.

6-1 To Remove Rotor:

Reference: Pump Assembly Section

1. Remove the coupling guard and disconnect coupling halves.
2. Disconnect any piping from the upper half casing (1B) that will interfere with its removal.
3. Remove bolting from the casing flanges and the bearing caps (41). **NOTE:** Some units are not provided with bearing caps. Remove bolting from the bearing bracket (31 & 33) and the lower case (1A).
4. Drain oil from the reservoirs (oil lubricated ball bearing units only).
5. Remove bolting through oil reservoirs (oil lubricated ball bearing units only). **NOTE:** On some units the oil reservoir is independent of the bearing housing. Remove the outboard oil reservoir with bolting (check Assembly Section).
6. Screw jackscrews down to separate upper and lower case. Turn jackscrews back after separation to prevent interference at reassembly.
7. Lift upper casing (1B) straight up until clear of the impeller.
8. Remove the bearing caps (41).
9. Remove the glands (17) and the gland bolts (170).
10. Place slings around the shaft near the bearing housings and lift rotating element from lower casing (1A).
11. Place rotating element in a clean, dry work area for necessary disassembly. Case wear rings (7) will be loose on assembly.

6-2 Disassembly of Rotating Element:

If the bearing assemblies do not require attention, but just the impeller or rings, then work just one side of the unit (impeller may be removed from either end).

1. Remove the pump half coupling.
2. Loosen setscrews in deflectors (40) and slide toward center of the pump.
3. Remove cap screws from the bearing covers (35 & 37) and separate covers from the bearing housings (31 & 33).
4. Remove bearing housings (31 & 33).

Section VI – Disassembly of Rotating Element Continued

5. Straighten locking tip on lockwashers (69) and remove locknuts (22) and washers.
6. Remove oil flings (172) and oil rings (60) – (oil lubricated ball bearings only).
7. Remove bearings (16 & 18). Remove with bearing puller pressing on the inside race. **Never** pull a bearing on the outside race unless the bearing is to be discarded.

NOTE: Items 8-10 refer to the sleeve bearing units only.

8. Remove thrust bearing cartridge (74), if applicable.
9. Remove oil rings (60).
10. Remove bolting from sleeve bearing halves (135 & 137) and remove bearings.
11. Remove bearing covers (35) and deflectors (40).
12. Remove packing (13), lantern ring (29), and stuffing box bushing (63), if applicable. Note the number of packing rings on either side of the lantern ring. The lantern ring (29) must be installed opposite seal water inlet. **NOTE:** Follow the seal manufacturer's instructions for repair and removal of mechanical seals.
13. Loosen setscrews in sleeve nut (20) and unscrew the nut from the shaft.
14. Remove o-ring packing (13A) and shaft sleeves (14).
15. Remove casing wear rings (7). On most pumps, casing rings may be removed before disassembling rotating element.
16. Impeller (2) with impeller rings (8) can now be removed from either end of the shaft.

CAUTION: When removing the impeller, note the direction of the vanes. The impeller must be installed with the vanes in the same direction.

6-3 To Remove Impeller Rings:

It is not necessary to remove the impeller from the shaft to replace the impeller rings. First remove the rotating element. Remove the locking set screws from the rings. The rings may now be pulled from the impeller, cut off with a chisel, or turned off, if a suitable lathe is available, using original shaft centers. **DO NOT CUT INTO THE BODY OF THE IMPELLER!** When new rings are installed, drill and tap new holes for the locking set screws – do not attempt to use old half holes in the impeller hub.

6-4 Inspection:

Visually inspect parts for damage affecting serviceability. Check o-rings and gaskets for cracks, nicks, or tears; packing rings for excessive compression, fraying or shredding, and embedded particles. Replace if defective in any way. Mount the shaft between lathe centers and check eccentricity throughout the entire length. Eccentricity should not exceed .002 inches. Bearing surfaces should be smooth and shoulders square and free of nicks.

Measure OD of impeller hub or impeller wear rings and ID of casing wear ring. Compute diametral clearance (ID minus OD) and compare with clearance given under the **Pump Specifications**. Surfaces must be smooth and concentric. Examine impeller passages for cracks, dents or embedded material. Examine shaft sleeves for wear.

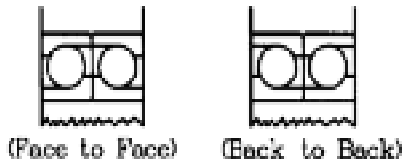

USING AN ARBOR PRESS

1. PLACE THE BEARING ON TWO FLAT BLOCKS SO THAT THEY CONTACT THE INNER RING OR BOTH RINGS OF THE BEARING
2. HOLD SHAFT STRAIGHT- FORCE THE SHAFT BY A STEADY PRESSURE UNTIL THE BEARING IS SEATED AGAINST THE SHAFT SHOULDER.

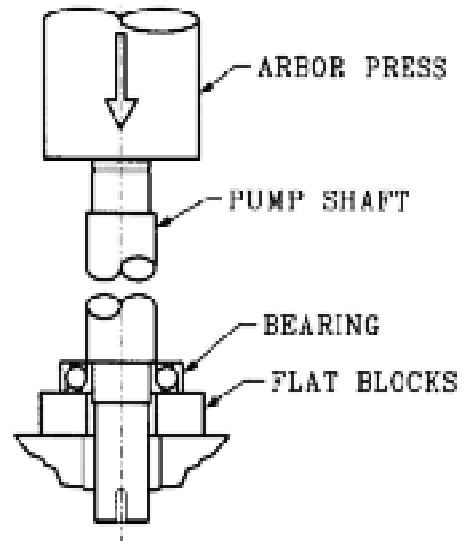

USING TUBING

1. PLACE THE BEARING ON SHAFT.
2. PLACE TUBING OVER SHAFT IN CONTACT WITH THE INNER RING OF THE BEARING.
3. APPLY HAMMER ALTERNATELY AT OPPOSITE POINTS- AVOID COCKING.

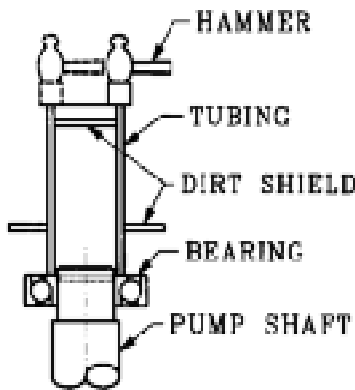

BEARING MOUNTING

USING A BEARING PULLER

1. PLACE BEARING PULLER BEHIND BEARING INNER RING. SET PULLER JAWS SO THAT THEY WILL NOT SLIP OVER THE INNER RING AND DAMAGE SEPARATOR OR SHILD WHEN PRESSURE IS APPLIED.
2. FORCE BEARING OFF SHAFT BY A STRAIGHT PULL. DO NOT COCK BEARINGS.

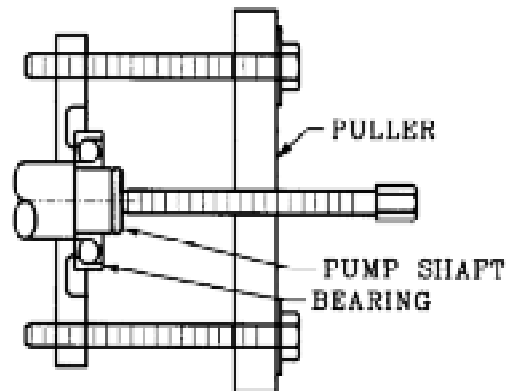

USING AN ARBOR PRESS

1. REST THE BEARING INNER RING OR BOTH RINGS (NEVER THE OUTER RING ONLY) AGAINST A PAIR OF FLAT BLOCKS.
2. FORCE THE SHAFT OUT BY A STEADY PRESSURE- KEEP SHAFT STRAIGHT- DO NOT ALLOW SHAFT TO COCK OR DROP.

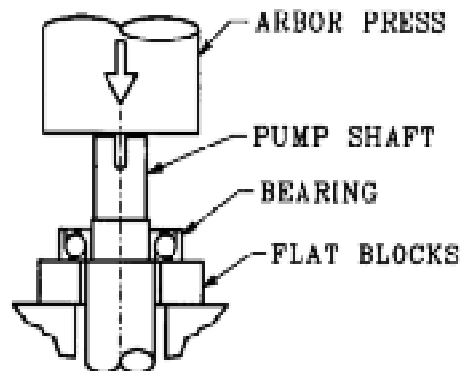

BEARING REMOVAL

FIGURE 9. BEARING REMOVAL AND MOUNTING

TABLE IV
BEARING DEFECTS

(Failures – Replace if found)

DEFECT (failure)	APPEARANCE	PROBABLE CAUSE
Flaking and cracking	In the early stages the surface of the inner and outer races develop small cracks, which flake. The cracks and flaking ultimately spread over the entire race surface.	<ol style="list-style-type: none"> 1. Normal fatigue failure. 2. Bearing loads in excess of bearing capacity caused by misalignment.
Indentations	Indentations or cavities in the inner and outer races.	<ol style="list-style-type: none"> 1. Dirt in the bearings. 2. Excessive impact loading of the bearings such as improper mounting or removal.
Broken separator (cage)	Cracked separator or separator in pieces.	<ol style="list-style-type: none"> 1. Poor lubrication. 2. Misalignment of shaft. 3. Excessive shaft deflection.
Wear	Bore and OD of outer ring of bearing galled or braided.	<ol style="list-style-type: none"> 1. Fit on shaft or in housing too loose. 2. Bearing locked by dirt and turning on shaft or in housing.
Fractured ring	Hairline cracks or complete ring fracture.	<ol style="list-style-type: none"> 1. Forcing a cocked bearing on or off a shaft. 2. Too heavy a press fit.
Discoloration	Balls and races darker than normal appearances of bearing metal. (Moderate discoloration of balls and races not a reason for discard).	<ol style="list-style-type: none"> 1. Inadequate lubrication.
Corrosion	Balls and raceways rusted.	<ol style="list-style-type: none"> 1. Water entering the housing. 2. Condensation inside the housing. 3. Lubricant breaks down into acid (wrong lubricant).

6-5 Assembly:

Assembly is the reverse of the disassembly procedure. The following should prove helpful in reassembling the pump:

1. All parts, inside and out, should be clean. Dirt and grit will cause excessive wear, plus needless shutdown.
2. Make certain that the keys are in their proper position.
3. Reinstall impeller with vanes in the right direction. Pump rotation is defined by viewing from the driver end. Impeller vanes slope must be opposite the pump rotation.
4. Do not lock sleeve nut (20) to the shaft until the impeller has been positioned in the center of the volute. This may be accomplished by loosening or tightening sleeve nuts against sleeves (14) as required, thereby working the impeller into position.
5. Make certain that the case rings (7) are in proper position. The half-raised ring should be on the outside and completely in the lower half casing (1A). Be sure the ring is fully seated.
6. Insure that the packing does not block seal water inlet.
7. Rotate by hand to insure that the parts do not bind before replacing upper half-case (1B).
8. Bearing mounting is simplified by heating the whole bearing, thereby expanding it enough to be slipped on the shaft. This heating is best done by submerging the bearing in a bath consisting of 10 – 15% soluble oil in water and heated to boiling. This mixture cannot be overheated, is non-flammable, drains off easily permitting convenient handling, and yet leaves an oil film sufficient for rust protection of the bearing surfaces.

LOCATING OPERATING DIFFICULTIES

In the majority of cases, operating difficulties are external to the pump and the following causes should be carefully investigated before undertaking repairs:

No Water Delivered

- Pump not primed – indicated by no pressure on discharge.
- Speed too low – indicated by low pressure on discharge.
- Valve closed – indicated by high discharge head.
- Impeller completely plugged up – indicated by low discharge pressure.

Abnormally Small Quantities Delivered

- Air leaks in suction pipe or stuffing boxes.
- Speed too low.
- Discharge head higher than anticipated.
- Impeller partially plugged up.
- Obstruction in suction line.
- Mechanical defects: casing rings worn, impeller damaged, casing or seal defective.

Insufficient Pressure

- Speed too low. Might be caused by low voltage or current characteristics different from nameplate reading on the motor.
- Air in water will cause the pump to make a cracking noise.
- Mechanical defects: worn casing rings, damaged impeller, defective casing or seal.

Intermittent Operation

- Leaky suction line.
- Water seal plugged (hence, a leaky stuffing box).
- Suction lift too high.
- Air, gas or vapor in liquid.

Pump Overloads Driver

- Speed too high.
- Head lower than rated, hence, pumping too much water. (This is valid for low specific speed pumps).
- Mechanical defects: stuffing boxes too tight, shaft bent, rotating element binds.
- Rubbing due to foreign matter in the pump between the case rings and the impeller.

Pump Vibrates

- Misalignment.
- Foundation not sufficiently rigid.
- Impeller partially clogged.
- Mechanical defects: bent shaft, rotating element binds, bearings worn, coupling defective.
- Suction and discharge pipes not anchored.
- Pump cavitating from too high a suction lift.
- Air entrainment in the pump suction due to low submergence.

RECOMMENDED SPARE PARTS FOR DOUBLE SUCTION PUMPS

Reference: Assembly Section

INTERMITTENT DUTY

Number	Description
7	Casing Ring
8	* Impeller Ring
13	* Packing (stuffing box)
13A	Packing O-Ring (shaft sleeve)
14	* Shaft Sleeve
65	+* Mechanical Seal (stationary element)
80	+* Mechanical Seal (rotating element)
	Coupling and its accessories (not shown)
	Gasket (not shown)
	Gland Bolts (not shown)

CONTINUOUS DUTY

Number	Description
2	Impeller
6	* Shaft
7	Casing Ring
8	* Impeller Ring
13	* Packing (stuffing box)
13A	Packing O-Ring (shaft sleeve)
14	* Shaft Sleeve
16	Bearing (inboard)
18	Bearing (outboard)
20	Shaft Sleeve Nut
20A	* Impeller Locknut
22	Bearing Locknut
32	Impeller Key
40	Deflector
46	Coupling Key
65	+* Mechanical Seal – Stationary Element
68	Shaft Collar
80	+* Mechanical Seal – Rotating Element
	Coupling and its accessories (not shown)
	All Hardware (not shown)
	Gasket (not shown)
	Gland Bolts (not shown)

* Determined by Pump Construction

+ Complete Consists of 65 & 80

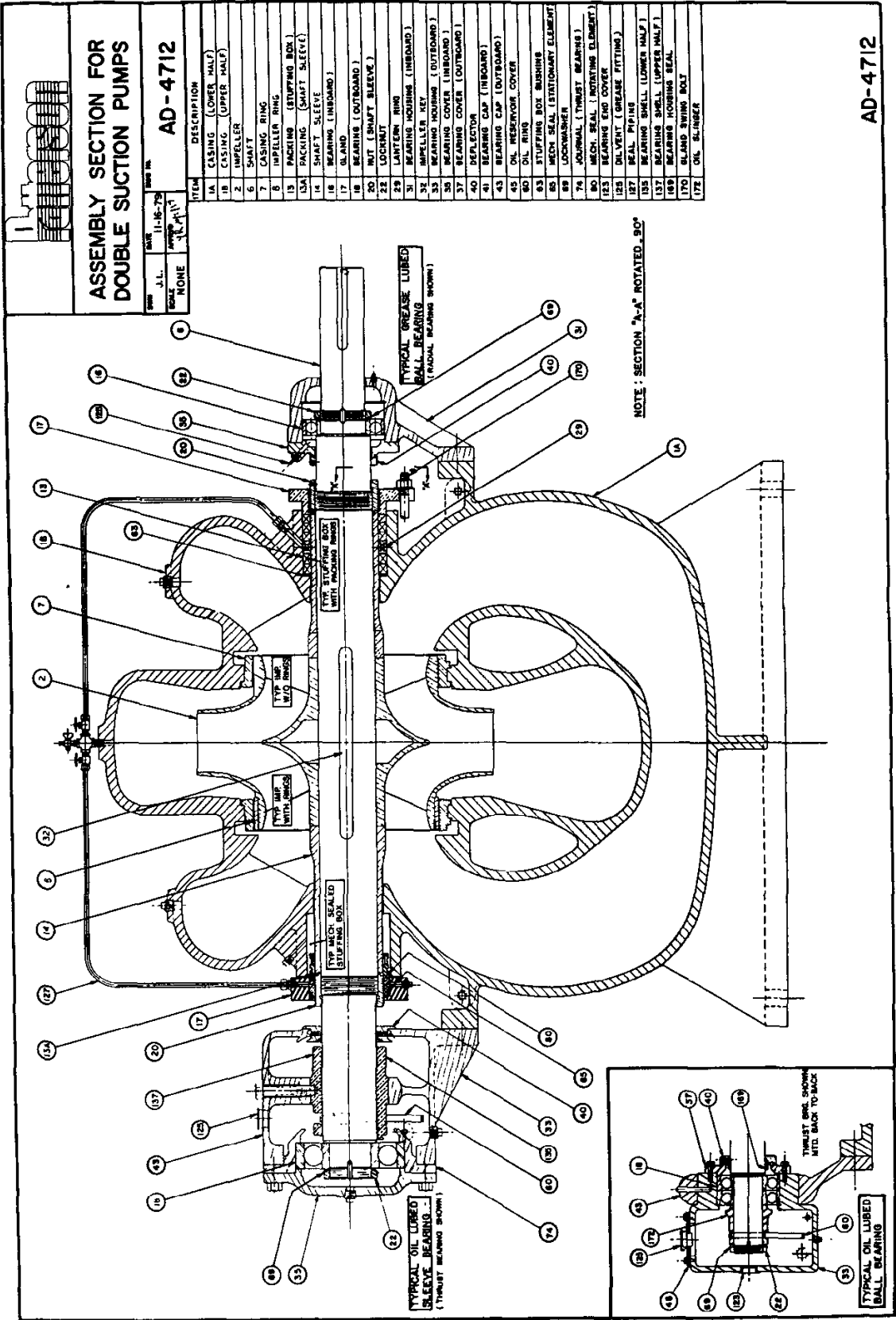

**ASSEMBLY SECTION FOR
DOUBLE SUCTION PUMPS**

AD-4712

DATE	BY	CHKD	REV
JUL 11 1967	J.L. RONE	J.L. RONE	1

ITEM	DESCRIPTION
1A	CASING (LOWER HALF)
1B	CASING (UPPER HALF)
2	IMPELLER
3	SHAFT
4	CASING RING
5	IMPELLER RING
6	PACKING (STUFFING BOX)
7	PACKING (SHAFT SLEEVE)
8	SHAFT SLEEVE
9	BEARING (INBOARD)
10	BEARING (OUTBOARD)
11	ISLAND
12	NUT (SHAFT SLEEVE)
13	LOCKWASHER
14	LANTERN RING
15	BEARING HOUSING (INBOARD)
16	IMPELLER KEY
17	BEARING HOUSING (OUTBOARD)
18	BEARING COVER (INBOARD)
19	BEARING COVER (OUTBOARD)
20	DEFLECTOR
21	BEARING CAP (INBOARD)
22	BEARING CAP (OUTBOARD)
23	OIL RESERVOIR COVER
24	OIL RING
25	STUFFING BOX WASHING
26	Mech. Seal (Stationary Element)
27	LOCKWASHER
28	JOURNAL (THRUST BEARING)
29	BEARING END COVER
30	OIL VENT (GREASE FITTING)
31	SEAL PIPE
32	BEARING SHELL (LOWER HALF)
33	BEARING SHELL (UPPER HALF)
34	BEARING HOUSING SEAL
35	ISLAND BRASS BOLT
36	OIL FLANGE

NOTE: SECTION "A-A" ROTATED 90°

(TYPICAL ONLY)

AD-4712

